

BLUE STAR

Power Systems Inc.

Diesel Product Line

208-600 Volt

VD200-02FT4

60 Hz / 1800 RPM

200 kWe / 200 kWe

Standby / Prime

Ratings

	240V	208V	240V	480V	600V
Phase	1	3	3	3	3
PF	1.0	0.8	0.8	0.8	0.8
Hz	60	60	60	60	60
Generator Model	433CSL6216	431CSL6208	431CSL6208	431CSL6206	431PSL6243
Connection	12 LEAD ZIG-ZAG	12 LEAD WYE	12 LEAD DELTA	12 LEAD WYE	4 LEAD WYE
Standby					
kWe	200	200	200	200	200
AMPS	833	695	602	301	241
Temp Rise	105°C / 40°C	105°C / 40°C	105°C / 40°C	105°C / 40°C	105°C / 40°C
Prime					
kWe	200	200	200	200	200
AMPS	833	695	602	301	241
Temp Rise	105°C / 40°C	105°C / 40°C	105°C / 40°C	105°C / 40°C	105°C / 40°C

Standard Equipment

- | | | |
|---|--|---|
| <p>Engine</p> <ul style="list-style-type: none"> ▶ Radiator Cooled Unit Mounted (55°C) ▶ Blower Fan & Fan Drive ▶ Starter & Alternator ▶ Oil Pump & Filter ▶ Oil Drain Extension w/Valve ▶ Governor - Electronic Isochronous ▶ 24V Battery System & Cables ▶ Air Cleaner (Dry Single Stage) ▶ Flexible Fuel Connector ▶ EPA Certified Tier 4 Final <p>Listing Certifications</p> <ul style="list-style-type: none"> ▶ UL 2200 Listed ▶ cUL Listed ▶ CSA Certified ▶ Seismic Certified to IBC 2012 | <p>Generator</p> <ul style="list-style-type: none"> ▶ Brushless Single Bearing ▶ Automatic Voltage Regulator ▶ ± 1% Voltage Regulation ▶ 4 Pole, Rotating Field ▶ 105°C Standby Temperature Rise ▶ 105°C Prime Temperature Rise ▶ 100% of Rated Load - One Step ▶ 5% Maximum Harmonic Content ▶ NEMA MG 1, IEEE and ANSI Standards Compliance for Temperature Rise | <p>Additional</p> <ul style="list-style-type: none"> ▶ Microprocessor Based Digital Control ▶ Interface Connection Box ▶ Control Panel Mounted in NEMA 12 Enclosure ▶ Base - Formed Steel ▶ Main Line Circuit Breaker Mounted & Wired ▶ SCR Catalyst / Silencer Mounted ▶ Battery Charger 24V 5 Amp ▶ Jacket Water Heater -20°F 3000W 240V w/Isolation Valves ▶ Vibration Isolation Mounts ▶ Radiator Duct Flange (OPU Only) ▶ Single Source Supplier ▶ 2YR / 2000HR Standby Warranty ▶ 1YR / 1500HR Prime Warranty ▶ Standard Colors - White / Tan / Gray |
|---|--|---|

Application Data

Engine			
Manufacturer:	Volvo Penta	Displacement - Cu. In. (lit):	661 (10.8)
Model:	TAD1170VE	Bore - in. (cm) x Stroke - in. (cm):	4.84 (12.3) x 5.98 (15.2)
Type:	4-Cycle	Compression Ratio:	17.0:1
Aspiration:	Turbo Charged, CAC	Rated RPM:	1800
Cylinder Arrangement:	6 Cylinder Inline	Max HP Stby (kWm):	320 (235)

Exhaust System	Standby	Prime
Gas Temp. (Stack): °F (°C)	775 (413)	775 (413)
Gas Volume at Stack Temp: CFM (m³/min)	1,564 (44.3)	1,564 (44.3)
Maximum Allowable Exhaust Restriction (Post SCR Cat.): in. H ₂ O (kPa)	28.0 (7.00)	28.0 (7.00)
Cooling System		
Ambient Capacity of Radiator: °F (°C)	131 (55.0)	131 (55.0)
Maximum Allowable Static Pressure on Rad. Exhaust: in. H ₂ O (kPa)	0.50 (0.12)	0.50 (0.12)
Water Pump Flow Rate: GPM (lit/min)	96.0 (372)	96.0 (372)
Heat Rejection to Coolant: BTUM (kW)	6,824 (120)	6,824 (120)
Heat Rejection to CAC: BTUM (kW)	2,843 (50.0)	2,843 (50.0)
Heat Radiated to Ambient: BTUM (kW)	2,419 (42.3)	2,419 (42.3)
Air Requirements		
Aspirating: CFM (m³/min)	745 (21.1)	745 (21.1)
Air Flow Required for Rad. Cooled Unit: CFM (m³/min)	16,725 (480)	16,725 (480)
Air Flow Required for Heat Exchanger/Rem. Rad. CFM (m³/min)	Consult Factory For Remote Cooled Applications	
Fuel Consumption		
At 100% of Power Rating: gal/hr (lit/hr)	14.9 (56.4)	14.9 (56.4)
At 75% of Power Rating: gal/hr (lit/hr)	11.6 (44.0)	11.6 (44.0)
At 50% of Power Rating: gal/hr (lit/hr)	8.29 (31.4)	8.29 (31.4)
DEF Consumption (% of fuel consumption)	± 6.00%	± 6.00%
Fluids Capacity		
Total Oil System: gal (lit)	9.77 (37.0)	9.77 (37.0)
Engine Jacket Water Capacity: gal (lit)	4.50 (17.0)	4.50 (17.0)
System Coolant Capacity: gal (lit)	10.20 (38.6)	10.20 (38.6)
DEF Tank Capacity: gal (lit)	18.5 (70.0)	18.5 (70.0)

Deration Factors

Rated Power is available up to 2,300 Ft (700m) at ambient temperatures to 122°F (50°C) standby and prime. Consult factory for site conditions above these parameters.

DGC-2020 Control Panel

Standard Features

- ▶ Digital Metering
- ▶ Engine Parameters
- ▶ Generator Protection Functions
- ▶ Engine Protection
- ▶ CAN Bus ECU Communications
- ▶ Windows-Based Software
- ▶ Multilingual Capability
- ▶ Remote Communications to RDP-110 Remote Annunciator
- ▶ 16 Programmable Contact Inputs
- ▶ Up to 15 Contact Outputs (7 standard)
- ▶ UL Recognized, CSA Certified, CE Approved
- ▶ Event Recording
- ▶ IP 54 Front Panel Rating with Integrated Gasket
- ▶ NFPA 110 Level 1 Compatible

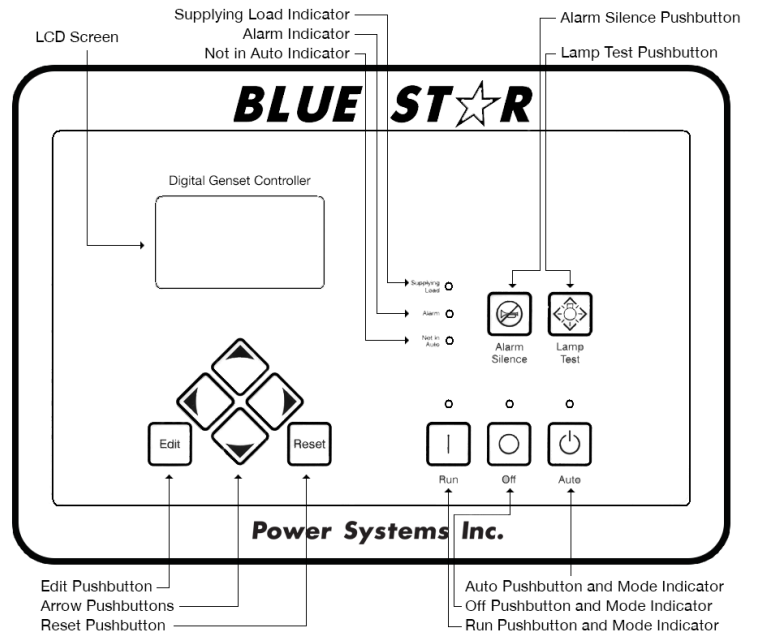

Weights / Dimensions / Sound Data

	L x W x H	Weight lbs
OPU	120 x 66 x 74 in	5,675
Level 1	156 x 66 x 94 in	6,575
Level 2	156 x 66 x 94 in	6,625
Level 3	196 x 66 x 94 in	6,900

Please allow 6-12 inches for height of exhaust stack.

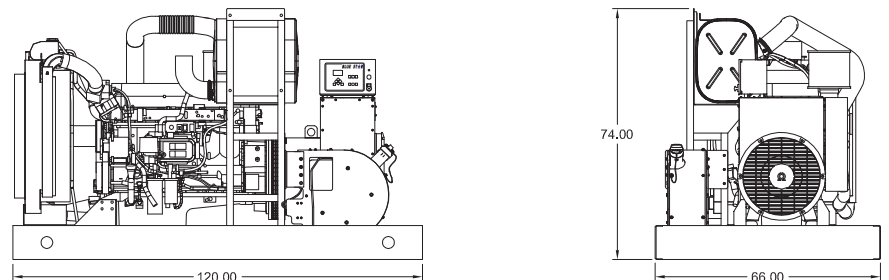
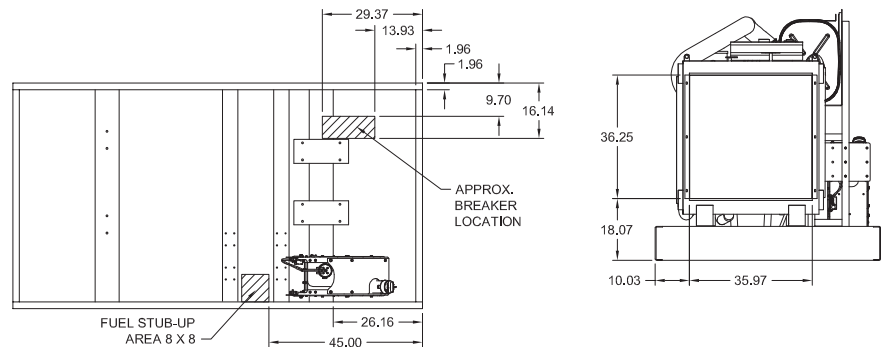

	No Load	Full Load
OPU	81 dBA	84 dBA
Level 1	77 dBA	79 dBA
Level 2	73 dBA	76 dBA
Level 3	69 dBA	71 dBA

Drawings based on standard open power 480 volt standby generator. Lengths may vary with other voltages. Subject to change without notice. Sound data as measured at 23 feet (7 meters) in accordance with ISO 8528-10 at standby rating.

Enclosures

Level 1 & 2 | Side View (Weather Proof)

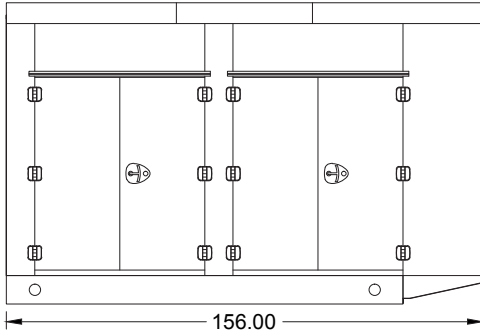

Level 3 | Side View (Sound Attenuated)

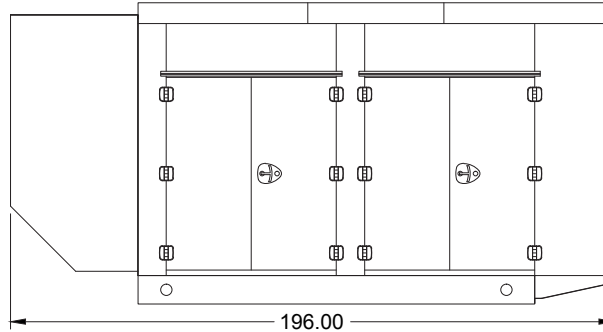

Level 1, 2 & 3 | Intake View

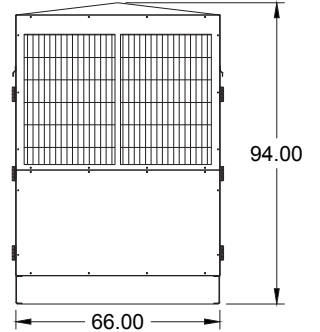

All enclosures are 150 MPH Wind Rated.

Level 2 & 3 enclosures include sound attenuation foam.

Level 3 enclosure includes frontal sound & exhaust hood.

*Enclosure height does not include exhaust stack.

Double Wall UL 142 Listed Fuel Tanks

Side View

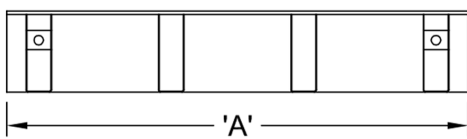

Rear View

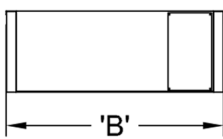

	24 Hour 375 Gallon	48 Hour 750 Gallon	72 Hour 1125 Gallon
A	120.00	120.00	162.00
B	66.00	66.00	66.00
C	18.00	36.00	36.00

All specification sheet dimensions are represented in inches.

All enclosures and fuel tanks are based on the standard standby unit configuration. Any deviation can change dimensions.

Materials and specifications subject to change without notice.

American Owned



American Made

Distributed By:

Blue Star Power Systems, Inc.

52146 Ember Road

Lake Crystal, Minnesota 56055

Phone + 1 507 726 2508

bluestarps.com

quote.bluestarps.com

sales@bluestarps.com